

KOTŁOSPAW Sp. z o.o.
UL. SZENICA 38, 63-300 PLESZEW
tel. +48-600-494-315
handlowy@kotlospaw.pl



KOTŁOSPAW

OPERATION AND MAINTENANCE DOCUMENTATION
Operation and installation manual

Pellet burner type "Easy ROT"

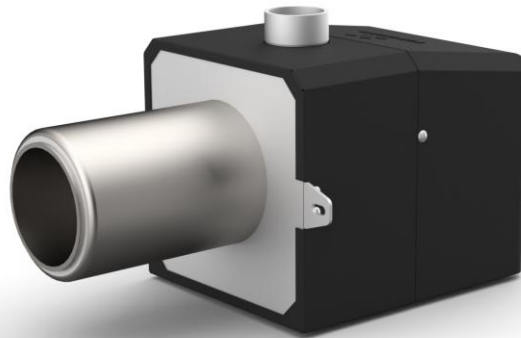

ORIGINAL
Edition I
May 2024

Dear customer

thank you for choosing our product.

We hope that the product you have chosen

will meet all your expectations.

Before you install and start using the burner, please read this documentation carefully.

The burner starting, periodic inspections and adjustment must be carried out by the authorised service personnel of Kotłospaw or companies with valid authorization to perform service work.

To book a service technician visit, the User should send this report to:

www.kotlospaw.pl/serwis/zgloszenie-serwisowe/

NOTE: In case of any doubts or other suggestions concerning the information in this manual, please contact us at handlowy@kotlospaw.pl

Always operate the device in accordance with the applicable regulations and standards.

TABLE OF CONTENTS

1. STORAGE	4
2. PRODUCT DESCRIPTION	4
2.1 Operation mode	4
2.2 Protections	5
3. BURNER STRUCTURE	5
4. SET COMPOSITION	7
5. INSTALLATION AND START-UP	7
5.1 Vertical feeder structure	9
5.2 Burner installation	12
5.3 Controller installation	13
5.4 Burner start-up	13
6. RECOMMENDED FUEL	13
7. BURNER OPERATION	14
8. BURNER INSPECTION	14
8.1 Removal of components	14
9. ELECTRICAL DIAGRAM OF BURNER	15
10. POSSIBLE FAULTS	16
11. WARRANTY CONDITIONS	17
12. WARRANTY PERIOD	19
13. BURNER COMMISSIONING REPORT (SCAN IS TO BE SENT BACK TO KOTŁOSPAW)	20

1. STORAGE

The purchased device should be stored under dry conditions i.e. at humidity not more than 65% and at temperature between +10°C-40°C. The device should not be stored at rooms with increased concentration of gases and dust that can be blown. Flammable materials cannot be stored within 1 metre from the device.

The device warranty starts from the purchase date of the burner by the Customer, but not later than one year from the device manufacture date.

2. PRODUCT DESCRIPTION

Easy ROT is the high class pellet burner characterised by advanced technology, low power consumption and high reliability. The burners are equipped with the rotary combustion chamber owing to which biomass burning is carried out continuously with the burner cleaning during its operation. The burner operation is maintenance-free which means that individual processes such as firing up, operation, cleaning or burning off are carried out automatically. Thanks to the rotary combustion chamber, the burner furnace is characterised by increased service life because of uniform furnace load during operation.

2.1 Operation mode

The burner provided with the controller has a special operation algorithm owing to which combustion and operation efficiency is high and the device requires no further user intervention. The following stages are distinguished:

* Firing up – filling the pellet burner with a starting dose and simultaneous start-up of the igniter and fan to initiate a fire in the furnace.

When the optical sensor, located in the burner, detects a flame in the furnace, after a while the boiler switches to the next operation mode.

* Operation – after successful firing up and maintaining a flame at the appropriate level, the controller automatically feeds subsequent fuel doses and controls airflow operation so as to produce an appropriate power. After firing up, the burner works with minimum power and depending on heat demand it modulates power up to full power it can produce.

Rotation of the furnace chamber is carried out cyclically owing to which combustion efficiency is at high level and results in spontaneous discharge of burnt pellets outside the burner.

* Burning off – when the burner reaches the required temperature shown on the controller, it switches to the burning off mode. In this mode fuel is no longer fed and only fan works and rotation of the furnace chamber is carried out cyclically. Thanks to that pellet remains are burnt completely. When the flame, monitored by the optical sensor, drops below the firing up threshold and remains for a while, the boiler switches to the next mode.

* Cleaning – the last stage of the burner operation during which rotation of the chamber is carried out continuously and the fan operates with increased efficiency to remove accumulated ash and slag from the burner furnace. When the flame parameter remains below the detection threshold for quite a while, the burner is turned off.

* Pause – the mode in which the burner waits for a possible firing up command that may result e.g. from temperature drop in the boiler or the start signal from the room thermostat.

* Failure – the mode that occurs when there are problems with the device or its components.

2.2 Protections

The burner has a number of protections so that in case of missing of the operational activities the user is informed about it with an appropriate message on the boiler controller and the device itself can stop working in a safe and controlled manner. The burner is provided with the following protection solutions:

- burner temperature sensor, installed in the feed pipe, with fast and precise temperature measurement. In case of temperature increase, the sensor transmits this information to the boiler controller that turns on the internal feeder and turns off the external feeder in order to burn the remaining fuel and switch to the "Failure" mode.
- special system for overpressure combustion and air distribution in the burner, causing pressure to be generated in the direction opposite to the fuel supply to the burner,
- spiro feed pipe that is flame retardant and it melts immediately in case of flashback, mechanically interrupting the fuel supply to the burner,
- tightness of the feeding system, which prevents reverse draft and therefore a risk of exhaust gas backflow is minimised.

3. BURNER STRUCTURE

The burner can be divided into two parts: the electrical plate on which there are all electronics of the burner and the mechanical plate on which there are steel elements of the burner. That separation prevents the electrical components from overheating and has a positive effect on their failure-free operation. The burner is made of stainless and heat resistant steel that is tested at temperatures up to 980°C. The feeder pipe is made of black steel and is additionally galvanised to prevent the element from corroding even after many years of operation.

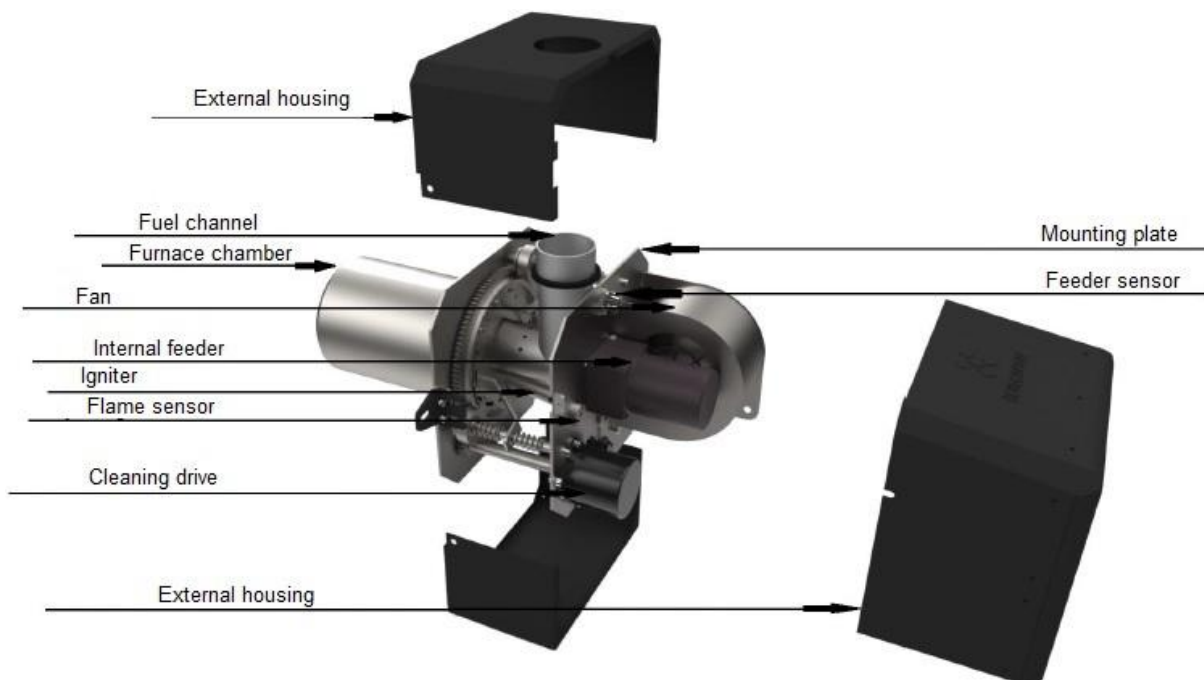

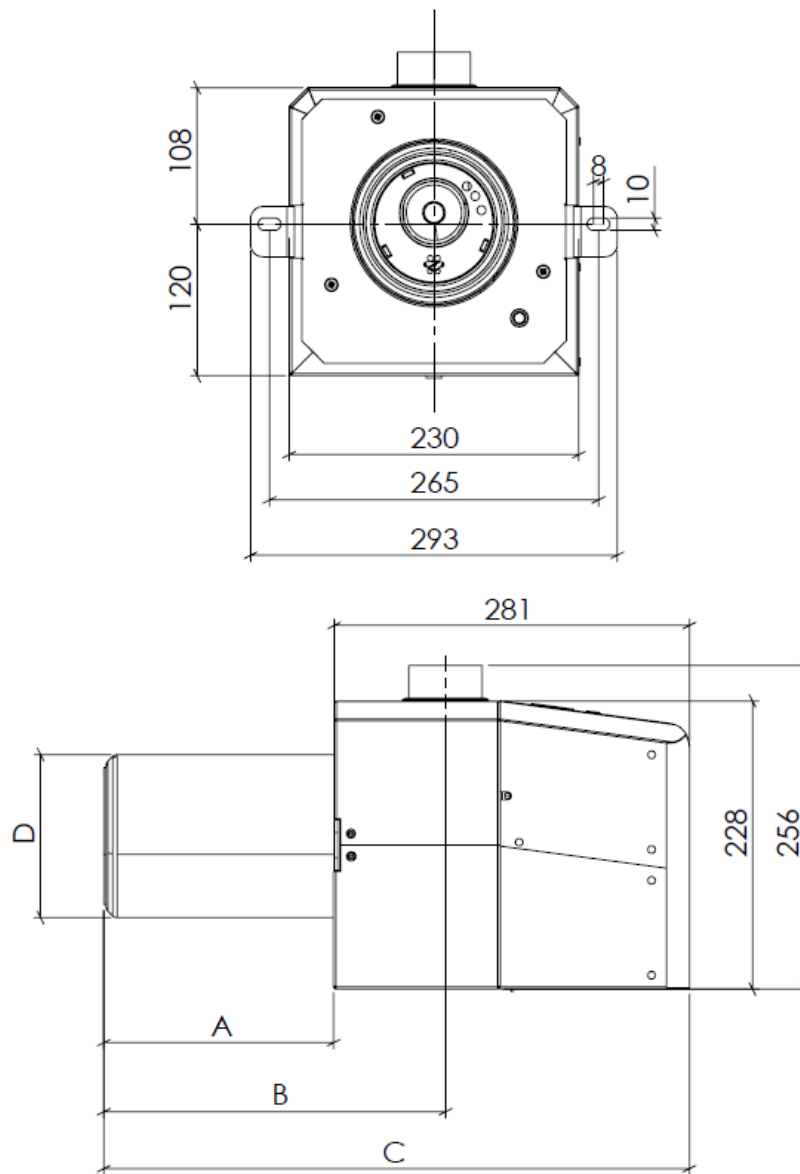

Model:	Power range:	Maximum power consumption: (Firing up/operation)	Weight	A [mm]	B [mm]	C [mm]	D [mm]
Easy ROT 10	3-10 kW	300 / 70W	11 kg	185	274	465	Ø129
Easy ROT 20	6-20 kW	300 / 70W	11 kg	185	274	465	Ø129
Easy ROT 25	8-25 kW	300 / 70W	13 kg	215	304	495	Ø129
Easy ROT 35	12-35 kW	300 / 70W	15 kg	238	327	518	Ø140

4. SET COMPOSITION

- pellet burner,
- galvanised pellet feeder,
- flame retardant spiro flexible pipe,
- Plum EcoMAX 860P4-KT controller,
- ceramic seal,
- Operation and Maintenance Documentation and warranty card

5. INSTALLATION AND START-UP

NOTE! The device should be installed by a company having the appropriate qualifications and experience in this kind of devices. For commissioning of the device it is required to call the Kotłospaw service personnel that shall carry out the necessary adjustments and configurations of the device and provides training for future users in addition to verifying the correct installation of the device.

The biomass burners are most frequently used in the central heating boilers, but they can also be installed in the bakery ovens, oil boilers or even gas boilers. The burner should be installed in the appliance being modernized in such a way to ensure its trouble-free service and maintenance. It should also be noted that the hole, where the Easy Rot burner is to be installed, is +/-15mm larger because of possible material expansion during operation.

NOTE! Do not start the firing up function when the furnace and spiro pipe are empty. This may cause an explosion!!

It is also very important to maintain the dimensions of the furnace chamber depending on the burner power:

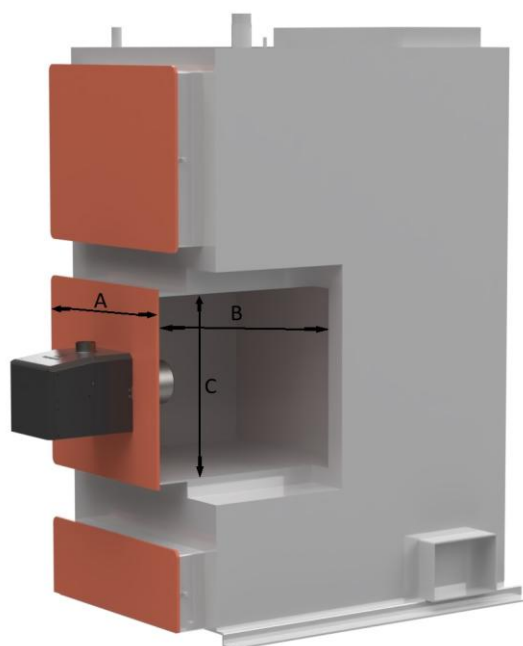

Location of the burner in the boiler

Example minimum dimensions of the furnace chamber

Burner type	Width „A” [mm]	Depth „B” [mm]	Height „C” [mm]
Easy Rot 10 kW	170	200	300
Easy Rot 20 kW			350
Easy Rot 25 kW			380
Easy Rot 35 kW	180	260	420

Pressure in the combustion chamber

Burner type	Pressure [mbar]
Easy Rot 10 kW	0.15
Easy Rot 20 kW	
Easy Rot 25 kW	
Easy Rot 35 kW	0.20

5.1 Vertical feeder structure

The vertical feeder is delivered in parts for customer self-assembly. Owing to that it is possible to plan the boiler room appearance and arrangement already at the preparation stage.

The vertical feeder structure is presented in the drawing below:



There is also a second type of the feeder i.e. horizontal one:

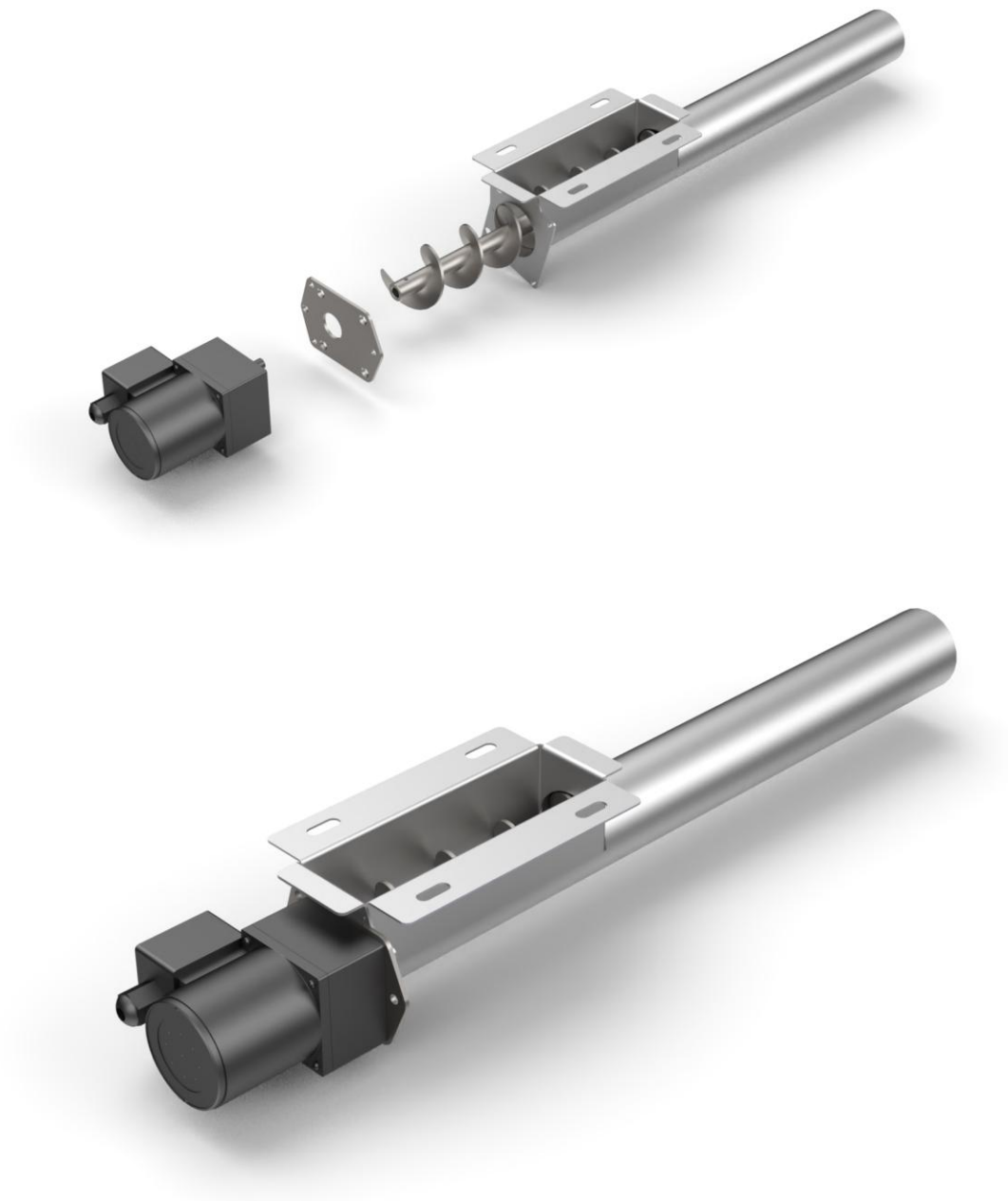

When the vertical feeder is used, attention should be paid that an angle between the auger feeder and the ground is approx. 45°:

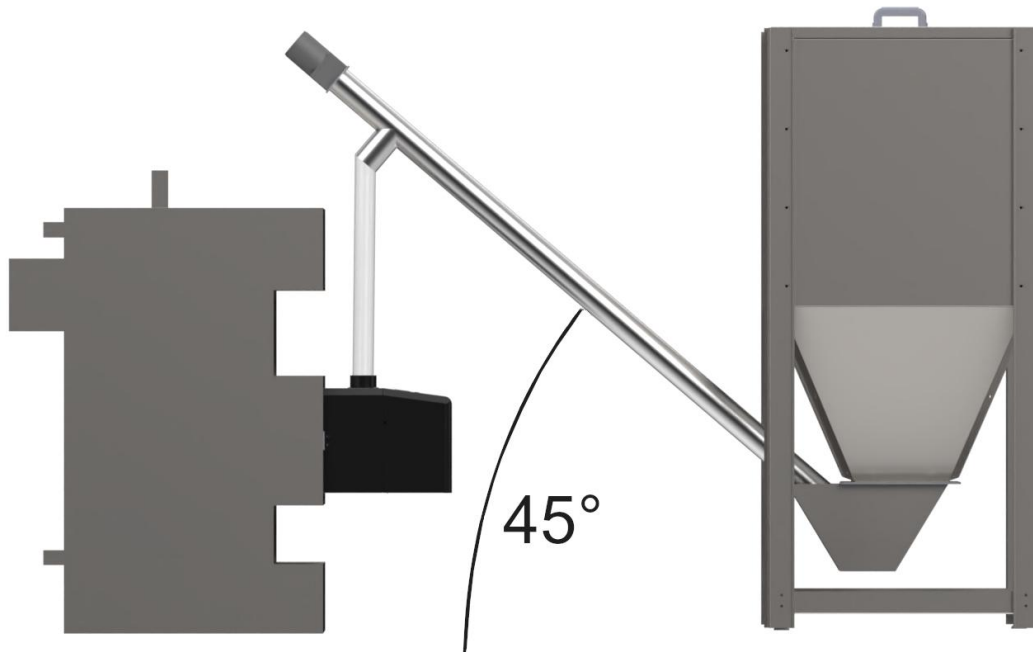

Depending on the needs, the feed pipe can be shortened. Then you must remember about the correct proportion of the auger protruding in the feeder chamfer. The auger protruding too long may cause pellet grinding, irregular fuel doses and even the hopper damage. Too short auger may cause problems with firing up or operation and pellet grinding.

The correct proportion is shown in the drawing below:



The feeder should be installed securely to the fuel bunker so that the user cannot accidentally change the inclination angle of the feeder. Most often, these types of feeders are suspended on the steel chains directly to the fuel bunker. It is required to install a spiro flexible pipe between the burner and the feeder. Attention should be paid that the pipe is not too long and its angle is not too gentle because pellets must move by gravity (they cannot bridge).

5.2 Burner installation

The burner is provided with two holes used for mounting it in the hole. The ceramic seal should be placed between the burner and the hole to prevent the device against overheating.

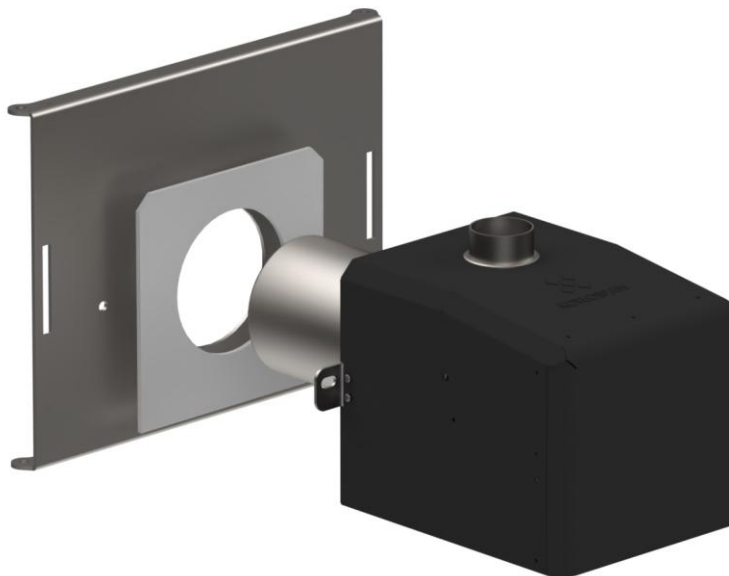

5.3 Controller installation

The controller should be installed in a location where the surface temperature does not exceed 50°C and the cables should be appropriately insulated and protected. The 12-PIN cable should be connected directly to the burner socket, paying attention to the dot that is located on the plug and cable and indicates the right direction of the plug installation. The next step is to connect the external feeder plug to the socket. Depending on the installation type, it may be required to connect additional sensors to the controller. The electrical diagram along with description can be found in the Operation and Maintenance Documentation of the EcoMAX 860P4-KT controller.

5.4 Burner start-up

NOTE! The device start-up must be carried out by the Kociołspaw service technician or the company appointed by the manufacturer. To report the need for a start-up, the user must send the report at: <https://kotlospaw.pl/serwis/zgloszenie-serwisowe/>

- 1) When the correct connection is made, connect the device to the mains. Check from the controller if all burner components work in the manual control and if burner and boiler temperature is displayed in the information.
- 2) The next step is to start the fuel feeder in the manual control until it is filled completely and pellets starts falling from the spiro pipe. After the correct filling with fuel, carry out the feeder calibration that is 6 minute performance test. The obtained value must be entered into the controller. The feeder calibration sequence can be found in the Boiler settings > Power modulation > feeder.
- 3) When the calibration is successfully completed, check whether there are any pellets in the spiro pipe and burner. In case there are any pellets in those places, pellets gasification may occur and therefore an explosion in the burner.
- 4) Once the above mentioned steps are completed, you can start operation of the burner. All details concerning the controller configuration can be found in the enclosed manual of the controller.

6. RECOMMENDED FUEL

The fuel used in the device should have the properties specified below:

Shape:	Pellets
Diameter:	6-8 mm
Length:	3-40 mm
Dust content:	≤1%
Bulk density:	≥620 kg/m ³
Humidity:	<8%
Calorific value:	16- 20 MJ/kg
Ash content:	≤0.7%
Quality standard:	DIN Plus/EN Plus

7. BURNER OPERATION

The Easy Rot burners should be used in accordance with this Operation and Maintenance Documentation, information contained in the warranty card and in accordance with generally accepted safety principles. The manufacturer is not responsible for damage caused by improper use. Please remember that the conditions in which the burner is used are in accordance with the regulations that is the boiler room is equipped with the supply and exhaust system specified by legal requirements according to the device power and the boiler room is free of dust or sawdust.

To ensure failure-free operation of the device, the user is obliged to check the device and clean the furnace manually if anything remains on it. Only use fuel that complies with the manufacturer's recommendations i.e. wood pellets with a valid DIN Plus or EN Plus certificate. When different quality pellets are used, the manufacturer shall not be responsible for any damage. It is an unacceptable situation when the burner head/furnace comes in contact with ash accumulating in the ash pan. Maintenance activities including manual cleaning of the burner should be carried out when the device is extinguished and disconnected from mains power.

8. BURNER INSPECTION

NOTE! The device inspection must be carried out by the Kotłospaw service technician or the company appointed by the manufacturer. To report the need for an inspection, the user must send the report at: <https://kotlospaw.pl/serwis/zgloszenie-serwisowe/>
Performing annual cyclical inspections affects not only combustion efficiency but also service life of components, which is specified in the extended warranty conditions and warranty conditions.

8.1 Removal of components

NOTE! Please remember to use original spare parts available from the manufacturer.

NOTE! Removal of components must be carried out when mains power is disconnected (the plug pulled out) and the burner 12 PIN socket is removed!

* Removal of burner housing

Clean the housing from dust and dirt.

* Removal of optical sensor

The optical sensor is responsible for reading the flame brightness. When there are problems with reading that value correctly, clean the optical sensor. Use a clean cotton cloth for its cleaning and wipe the glass itself gently so as to not scratch as this may result in irreversible damage to the sensor.

* Removal of electrical plate

* Removal of igniter

When the igniter breaks down, it can be replaced easily and quickly.

9. ELECTRICAL DIAGRAM OF BURNER

Burner board

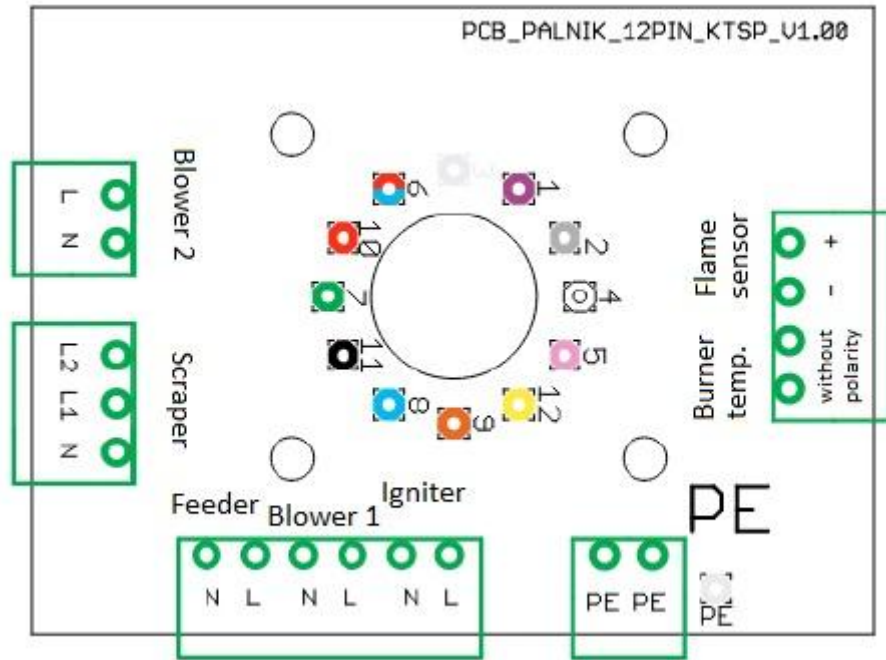



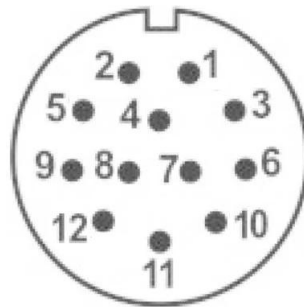

Socket in the burner board



Cable description

PIN	Wire colour	Actuating system	Graphic symbol	Voltage	Max. current	Pin in controller
1	Blue	Neutral		230V Neutral	2A	4
2	Black	Blower		230V Phase	2A	5
3	Red	Burner cleaning		230V Phase	3A	9
4	Red / blue	Not used		-	3A	-
5	Purple	Not used		-	2A	-
6	Pink / grey	Not used		-	0.8A	-
7	Pink	Burner temperature sensor (signal +)		+0.1V – 1.0V	0.8A	35

8	Grey	Flame sensor (signal +)	 OS	+1 – 5V	0.8A	33
9	White	Ground of sensors (GND)		-5V	0.8A	34
10	Brown	Igniter	 IG	230V Phase	3A	10
11	Green	Internal feeder	 FB	230V Phase	3A	12
12	Yellow	PE earthing	 UZ	GND		PE

10. POSSIBLE FAULTS

Alarm content	Possible causes
The burner failed to ignite and the display shows FIRING UP FAILED error	<ul style="list-style-type: none"> - No fuel left in the bunker – add fuel and fill the feeder pipe in the manual control mode; - Run a functional test of the igniter in the manual control mode. <p>If the igniter has failed, contact the service personnel;</p> <ul style="list-style-type: none"> - Check the burner grate for clogging with ash. Clean the grate manually if required; - Run a functional test of the external fuel feeder in the manual control mode. If the fuel feeder runs but it still fails to feed a sufficient dose of fuel, clean the charging hopper of the bunker and the feeder pipe; - Check that the igniter's tip (heat output aperture) is clearly visible. The use of poor quality pellets may obstruct the igniter; - Clean the photocell (carefully with a dry cloth).
The controller displays the FEEDER TEMPERATURE EXCEEDED alarm	<ul style="list-style-type: none"> - Check the patency of the flue gas duct and chimney connection; - Carefully inspect the patency of the boiler chamber, heat exchanger and smoke conduit - check the burner grate for excessive deposits of ash. Remove the ash manually if required. - Clean the burner fan, - Carry out the feeder calibration,
The blower and external feeder are	- The door opening limit switch has probably

inoperative	tripped. Close the boiler door, - The safety temperature limiter (STB) can be defective – contact the service personnel.
The boiler circulation pump fails to start when it reaches the start temperature	- The controller operates in the “Summer” mode – change the running mode to “Winter”
The controller does not function	Replace the fuse in the actuating system (the white junction box where wiring is connected to). Glass fuse 6.3A.
The burner smokes heavily and leaves soot inside the boiler	Insufficient oxygen or too much fuel dose: - Carry out the feeder calibration, - Increase amount of oxygen; - Check the grating slots and the combustion chamber panel vents for obstructions. If there is obstruction, unclog using the wire of diameter < 4 mm.
The combustion process leaves much slag	Low quality fuel: - It is recommended to change fuel to the appropriate one.

11. WARRANTY CONDITIONS

1. The warranty constitutes a commitment of the manufacturer of the boiler for a free removal of physical defects during its duration resulting from manufacturing defects.
2. The warranty repair will be carried out within 14 days from the date of its reporting. Reporting can be made by website or email.
3. Complaints should be submitted to the seller or manufacturer.
4. The claimant is obliged to reimburse the cost of the call if:
 - a device failure and its repair is due to the fault of the user,
 - calling the service to perform work not covered by the warranty, for example: correction of controller parameters depending on fuel types, fuse replacement,
 - repair not possible due to the reasons beyond the control of the service, such as no power supply to the burner system, no fuel, leaking central heating system, incorrect or damaged chimney flue, no access to operate the boiler,
 - difficulties in starting and operating the boiler due to improper fuel quality or burning not in accordance with the Operation and Maintenance Documentation.
5. The manufacturer chooses the method of removing the defect (repair, replacement of specific parts, replacement of the entire product).
6. The warranty is extended by the time that was required to remove the defect.
7. The condition for accepting a complaint is strict compliance with the provisions of the Operation and Installation Manual and the standards legally binding in Poland referred to therein.
8. Complaints will not be accepted in case of:

- incorrect installation of the central heating boiler system,
 - improper operation, lack of careful periodic cleaning,
 - unauthorized modifications and repairs,
 - any changes in the connections of the electrical system of the boiler or connection of additional control devices without the written consent of the manufacturer,
 - failure to perform the annual, mandatory inspections of the boiler and burner by the Kotłospaw Service.
9. You cannot claim the following:
- damage during transport by the customer,
 - damage resulting from faulty operation,
 - damage resulting from fortuitous events (flood, fire, etc.)
 - natural wear and tear of the device e.g. local deformation/crack of the furnace elements;
 - damage of the burner elements caused by overpressure in the burner e.g. no chimney draft, no air supply in the boiler room, grate contamination or boiler contamination,
 - defects caused by a failure to follow the manufacturer's requirements on starting the burner by the service and annual inspections of the device within the required period, the result of which is lack of the appropriate record in the warranty card of the device.
10. The warranty repairs do not cover seals, heat-resistant liners, ceramic rope, spiral pipe, burner temperature sensor, motor capacitors and burner sealing.
11. This warranty becomes void if interventions in the device design and/or structure are carried out by unauthorised persons and the use of spare parts other than those dedicated by Kotłospaw Sp. z o.o.
12. Complaints without the Warranty Card for the boiler, with the seal, date, and signature of the seller will not be accepted. When submitting a complaint, the manufacturer has the right to request photocopies of the Warranty Cards and a document confirming the purchase.
13. Settlement of a complaint should be confirmed by the report.
14. The warranty covers the territory of Poland. This warranty does not exclude, limit or suspend the buyer's rights arising from the non-compliance of the product with the contract.
15. The customer receives the basic 24-month warranty for the burner, while adhering to all the guidelines from the Operation and Maintenance Documentation of the burner. It is possible to extend the warranty up to 60 months - details in the table entitled "Extending the warranty".
16. Kotłospaw sp zoo. reserves the right to issue a one-time consent for a third party to replace parts and/or repair the device.

12. WARRANTY PERIOD

24 months	36 months	60 months *
- motors, - fan, galvanized steel elements, - sockets and plugs, - stainless and acid resistant steel elements	- igniter: 3 years or 3500 ignition cycles	- burner furnace chamber

SERVICE PRICE LIST

The current price list of maintenance services and the scope of service work can be found at:
https://kotlospaw.pl/assets_kotlospaw/uploads/Cennik-i-zakres-uslug-serwisowych.pdf

***WARRANTY EXTENSION**

The customer can take advantage of the extended warranty for the burner furnace up to 60 months if the device:

- is installed and used in accordance with the information contained in this Operation and Maintenance Documentation of the burner and controller,
- paid boiler/burner commissioning and paid annual inspections are performed by the Kotłospaw Service,
- has the filled in boiler/burner documents, especially the commissioning report and inspection schedule.

13. BURNER COMMISSIONING REPORT (SCAN IS TO BE SENT BACK TO KOTŁOSPAW)

User's first and last name		Model and power of the boiler	
Phone number		Serial number of the boiler	
Address		Year of production of the boiler	
		Serial number of the burner	

INSTALLER		SERVICE TECHNICIAN	
Phone number		Phone number	
Company's stamp		Company's stamp	

Check list	Data	Remarks
Supply and exhaust system	YES / NO	
Socket voltage and earthing	YES / NO	
Open-loop system acc. to the Operation and Maintenance Documentation	YES / NO	
Closed-loop system acc. to the Operation and Maintenance Documentation	YES / NO	
Room controller	YES / NO	
Chimney (ceramic / brick / other liner)		
Device for heat removal (closed-loop system)		
Safety valve [bar]		
Return protection		
EcoNET UID		

	Commissioning	First inspection	Second inspection	Third inspection	Fourth inspection
Date					
Feeder operation time [h]					
Operation time with min. power					
Operation time with average power					
Operation time with max. power					
Igniter					
Service technician's stamp					
REMARKS					

I declare that I have read the operating instructions for the device and the terms of the warranty. I acknowledge the manufacturer's recommendations to carry out technical inspections of the device. Moreover, I declare that I know the rules of proper operation and use of the boiler.

DATE AND USER SIGNATURE

.....

DECLARATION OF CONFORMITY



Kotłospaw Sp. Z o.o.
ul. Szenica 38
63-300 Pleszew

By signing this document we declare with full responsibility that the product:
Pellet burner of Easy ROT and Easy STEP with power: 10kW-500kW has been designed, manufactured and placed on the market in conformity with the following directives:

- Directive 2006/42/EC on machinery, (Journal of Laws (Dz.U.) No. 199/2008, item 2128),
- Directive 2004/108/EC on electromagnetic compatibility (EMC), (Journal of Laws (Dz.U.) No. 82/2007, item 556),
- Directive 2006/95/EC on low voltage devices (LVD), (Journal of Laws (Dz.U.) No. 155/2007, item 1089),
- Regulation (EU) 305/2011 of the European Parliament and of the Council and the following harmonised standards:
 - EN 60335-2-102
 - EN 60730-1:2012
 - EN 15270:2008E-1
 - PN-EN 60446:2008E-1
 - PN-EN 60519-2:2008
 - EN 953:1997+Al.:2009
 - PN-EN 60730-2-5:2006
- Technical documentation

The person authorised to issue the technical documentation: **Przemysław Wroński**.

This declaration will be rendered invalid if any changes are made to the product or it is reconstructed without our consent or it is used not in accordance with the operation manual.
In case of transfer of ownership rights to another person, this declaration must be handed over with the device and documentation.

Date:

Company owner

.....

.....

KOTŁOSPAW Sp. z o.o.
UL. SZENICA 38, 63-300 PLESZEW

Service Department:
+48-512-373-828
serwis@kotlospaw.pl

Sales Department:
+48-600-494-315
handlowy@kotlospaw.pl

